

## Telex To Hitachi Projector Change out Procedures

1. Remove the lower ABS shadow cover. This allows access to power strip and connections.
2. Unplug the projector power plug from power strip.
3. Unplug the projector cooling fan power plug
4. Disconnect and remove the video connector and cable going from roll rings to the projector. **Save, you will reinstall same later.**
5. Remove the four mounting bolts that are holding the upper shadow box , projector and mirror assembly to the cockpit canopy. **Save Hardware.**
6. Unpack and verify that all the parts are there that are called for in the installation instructions.
7. Reference drawing EDA-158. Using a marker that writes on fiberglass, measure and mark out the new opening for the Hitachi system.
8. **NOTE! You may want to wear a dust mask to prevent breathing the fiberglass dust for the next steps.**
9. Using a 5/16" drill, drill each corner of the new rectangle marked on the canopy.
10. Using a scroll saw, follow the inside edge of the marked lines and cut out the new rectangle.
11. Obtain a can of flat black enamel/lacer pray can.
12. Mask off the outside edge of the fiberglass opening, spray the edges of the new exposed glass. Remove tape when dry.

**Caution! Insure that you have control of the new projector and mounting assembly to prevent it from dropping to the ground causing serious damage to the projector and or mirror assembly.**

13. Holding onto the new projector assembly position the mirror end through the new opening in the upper canopy area. See drawing EDA-159.157.
14. Push upwards slightly to ensure mirror top tab is tight against the upper edge of the opening, while holding it there verify or mark the position of the mounting holes on projector back frame to the canopy back.
15. Drill new holes using a 5/16" drill and drill through the fiberglass, at points marked earlier.
16. Using hardware removed prior, position new projector over the drilled openings, install the bolts, washers, lock washers ,nuts and tighten.
17. Directly below the projector measure and mark where the two 1/4" cable clamps are to be fastened. See drawing EDA-157,159.
18. Using the new hardware fasten the clamps to the top two holes and tighten. These clamps will become cable tie points for new cables going to the new projector.
19. Install a 1/4" cable clamp under the lower left projector mount screw and tighten.
20. Plug projector power cord into projector on left side and route the cable past the left lower cable clamp, using a tie wrap secure cord to clamp. See drawing EDA-157.
21. Pre forming the power cord into a loop, secure the cord to the first clamp, lower left top ABS panel. Use tie wrap and tighten. Cut off waste end. See EDA-157.
22. Run power cable to the top right ABS clamp along with the fan power cord and the projector VGA/S video signal cable leaving a slight loop in signal and fan cable, tie wrap all to the clamp. See EDA-157 drawing for routing and tie points.

23. Run projector power cord, fan power cord and VGA signal cable along the backside of cockpit down to the lower cockpit area.
24. Plug projector power and fan power into cockpit power strip
25. Connect the VGA signal cable to the roll ring VGA output connector. Tighten setscrews and/or using tie wraps lock connectors together.
26. Place ribbed cable protector sleeve over the wires and dress up, secure wires to the back of the cockpit to prevent cable damage during motion.
27. Using patch cover provided in kit place it over the upper ABS hole that allowed access to the old projector controls and secure it with the hardware provided.
28. Turn lower cockpit power strip ON
29. Turn Inside A frame cockpit power strip ON
30. Ensure that the projector cooling fan is running
31. Remove the focusing lens protective cover door from new projector and store in a safe place.
32. Turn the projector power to ON, left side rear of projector. Toggle switch.
33. Using the remote control turn the projector to Standby and set up the projector per instructions provided and Hitachi projector manual.
34. Turn main computer ON as per normal procedures.
35. Get into the Program, make sure TV displays picture.
36. Verify that the screen inside has a picture. If Not, using the trouble shooting procedures for the projector reset the projector controls until a picture appears.
37. Using the remote and menus in the projector program set the values to the best picture.
38. Focus the projector for sharpest picture. Install Gum from old projector to prevent focus ring to turn.
39. Align image on the screen by following the image alignment procedure.

## New Hitachi CP-S220W Liquid Crystal Projector

### Safety:

1. Before removing the projector or performing any maintenance on the unit, switch the projector OFF and allow to cool for @ 25-45 minutes.
2. At end of day , using the remote, click POWER/STANDBY button and allow unit to cool down @ 5-10 minutes before removing cockpit power. This allows the projector lamp to cool down, extending the lamp service life.

### Turning Projector On

1. Ensure that the cockpit power switch on power strip is ON and power strip inside under the seats is ON, fans running.
2. Ensure that the power switch at left rear side of projector is ON (I) position, this places the projector in standby mode, power indicator will turn orange and all legend lights will be hi lited.
3. With the cockpit open, target the mirror with the projector remote;
  - a. Press the Standby/On button once, starting the projector lamp heating and warm-up mode, the power indicator will blink green, when the lamp comes on bright the power ON indicator will be on solid green.
  - b. Standing inside cockpit facing the mirror you can see the button indicators in the mirror. The buttons are back lighted orange, telling you that power is on.

### Turning the Projector Off

1. With the remote, point towards the mirror, and press Stby/On button once, the power indicator will start blinking orange.
2. When the orange blinking light goes on solid the lamp has cooled enough to allow cockpit power removal.
3. Turn cockpit power OFF system is shut down.

**NOTE:** If you turn power OFF to the projector without allowing lamp cooling time this will shorten the lamp life considerably.

### Servicing or replacing lamp

1. Switch the projector power off, allow to cool for at least 45 minutes, remove the power cord.
2. Purchase and prepare the new lamp. To find out where your closest dealer is in your area call HITACHI at 1-800-448-2244.
3. Check that the projector has cooled sufficiently;
  - a. Remove the external cooling fan enclosure by removing two screws on left lower side of projector enclosure.
  - b. Remove or ensure power plug has been removed on left side.
  - c. Remove the video input cable from rear of projector.
  - d. Loosen three metric bolts on the rear of the projector housing.
  - e. **NOTE Three spacers will fall down when the projector mount bolts are removed.**

- f. Having one person hold the projector, remove the three screws, there are three spacers that will also come out at this time. Place aside they will be reused upon install.
- g. Lay projector on flat surface backside up.
- h. Loosen two screws on the lamp cover, lower right corner and remove the cover.
- i. Loosen the one screw, and gently remove the lamp while holding the grips. Do not touch the inside of the lamp covering, this will cause discoloration of the cover.
- j. Install the new lamp in reverse order and tighten the one screw firmly. Steadily push the opposite corner of the lamp assembly while reinstalling in the housing.
- k. Replace the lamp cover and tighten the two screws
- l. Place projector near the power plug ensuring that it cannot fall and power up the projector to test the lamp.
- m. Remove power and power cord. Reinstall projector on the ride in reverse order of removal.
- n. Turn on and test unit completely.
- o. Go to Resetting the Lamp Timer.

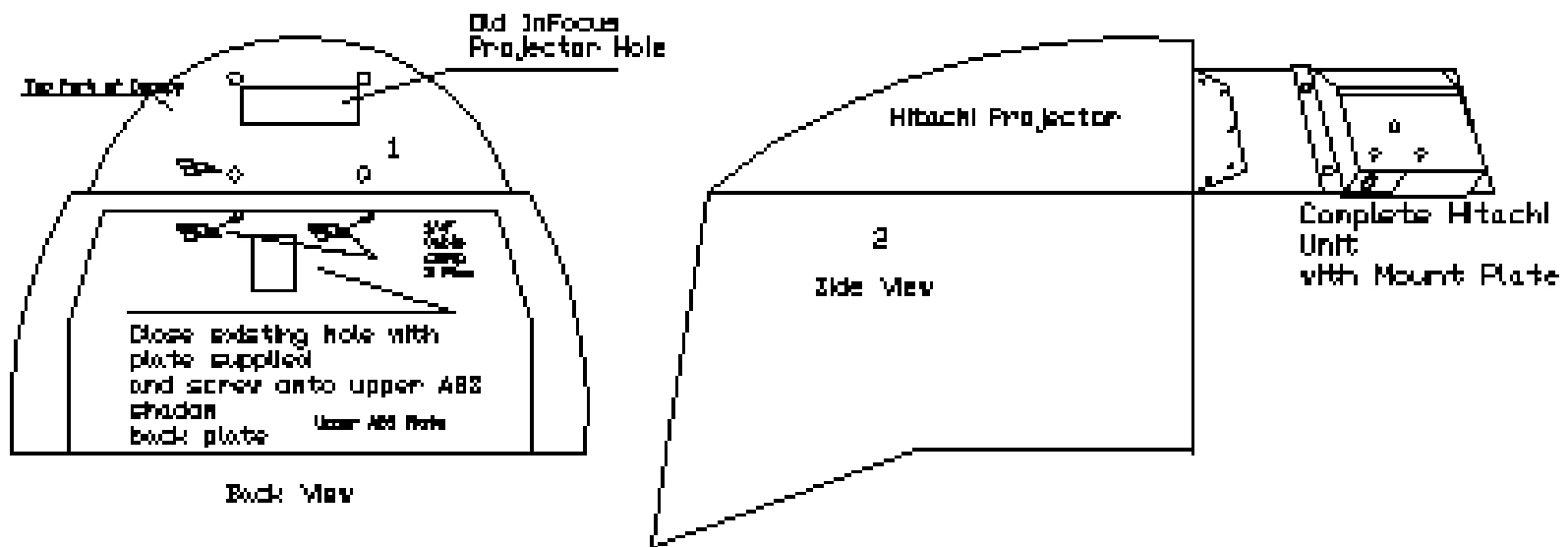

Remove Old System Completely  
 Install the new using written instructions

Infocus System to Hitachi  
 Change

EDA159

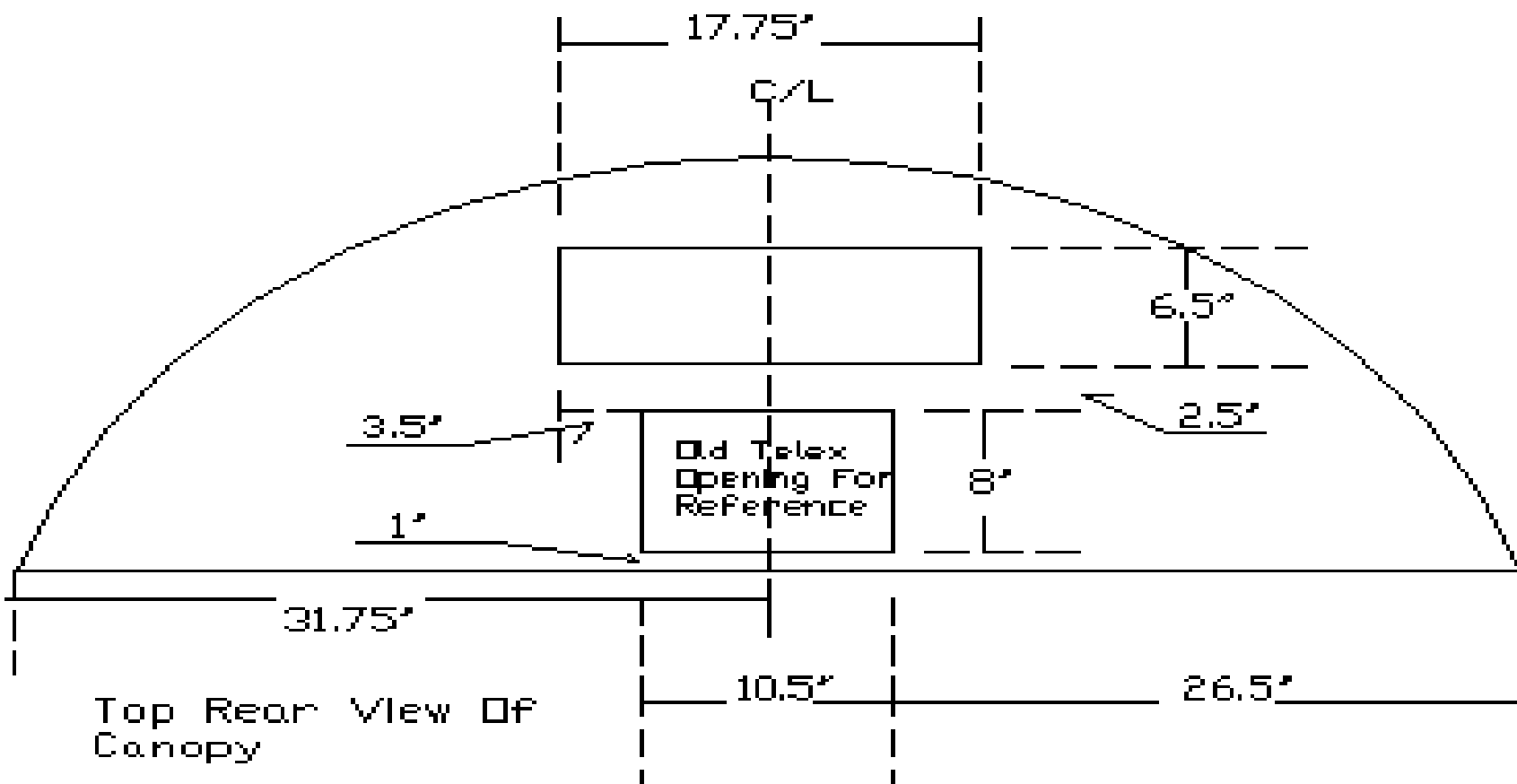

Top Rear View Of  
Canopy

Telex to Hitachi Conversion Rear Of  
Canopy Top

EDA158

